



Pioneer DreamMicro

Blade Server – **S75 Series**

---

# Advantage of Blade Server?

Easy Maintenance – Hot Swappable

High Availability – Redundant Architecture

Space Saving – Cableless



Rack Mount Server

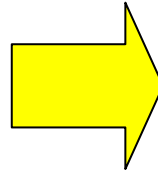

Blade Server

# Pioneer Blade Server



- 7U chassis
- 10 Server Blades
  - Intel Server Blade
- No Single Point Failure
  - Redundant Power, Cooling, CMM, I/O, etc
- Multiple I/O Technologies Support
  - GbE, FC, SAS Expander
  - Switch and Pass-Through Solutions
- Storage Solutions
  - SAN, NAS, DAS
- Integrated KVM Switch
  - Entry KVM,
  - Adv KVM (G01) –KVM over-IP
- Out-Of-Band Chassis Management
- Power Supply Unit: N+1 (2100W for each)
- Mid-plane: 100% Passive

# Front View

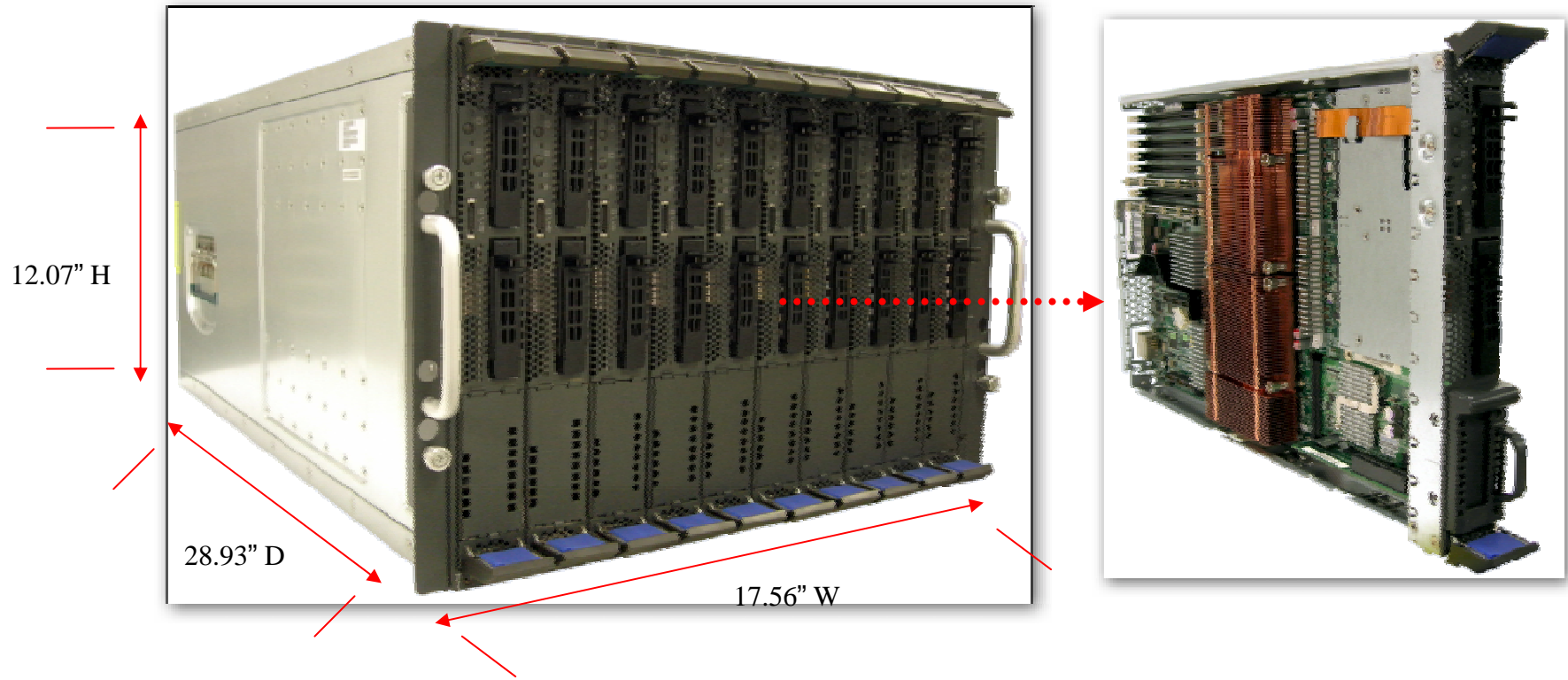

One System Supports Up to **10** Server Blades

# Rear View

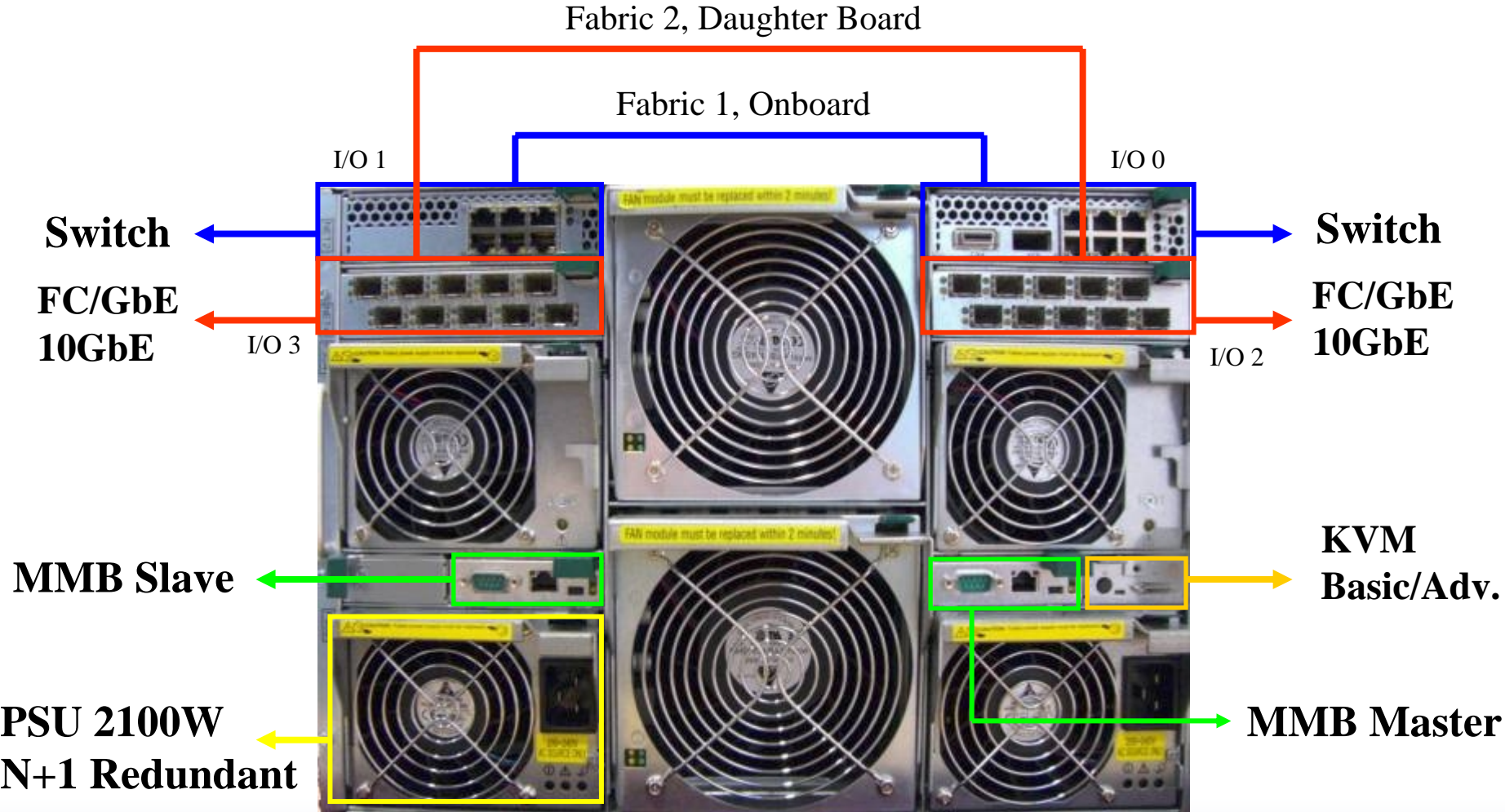

# Structure

## The View of Chassis Side Handle

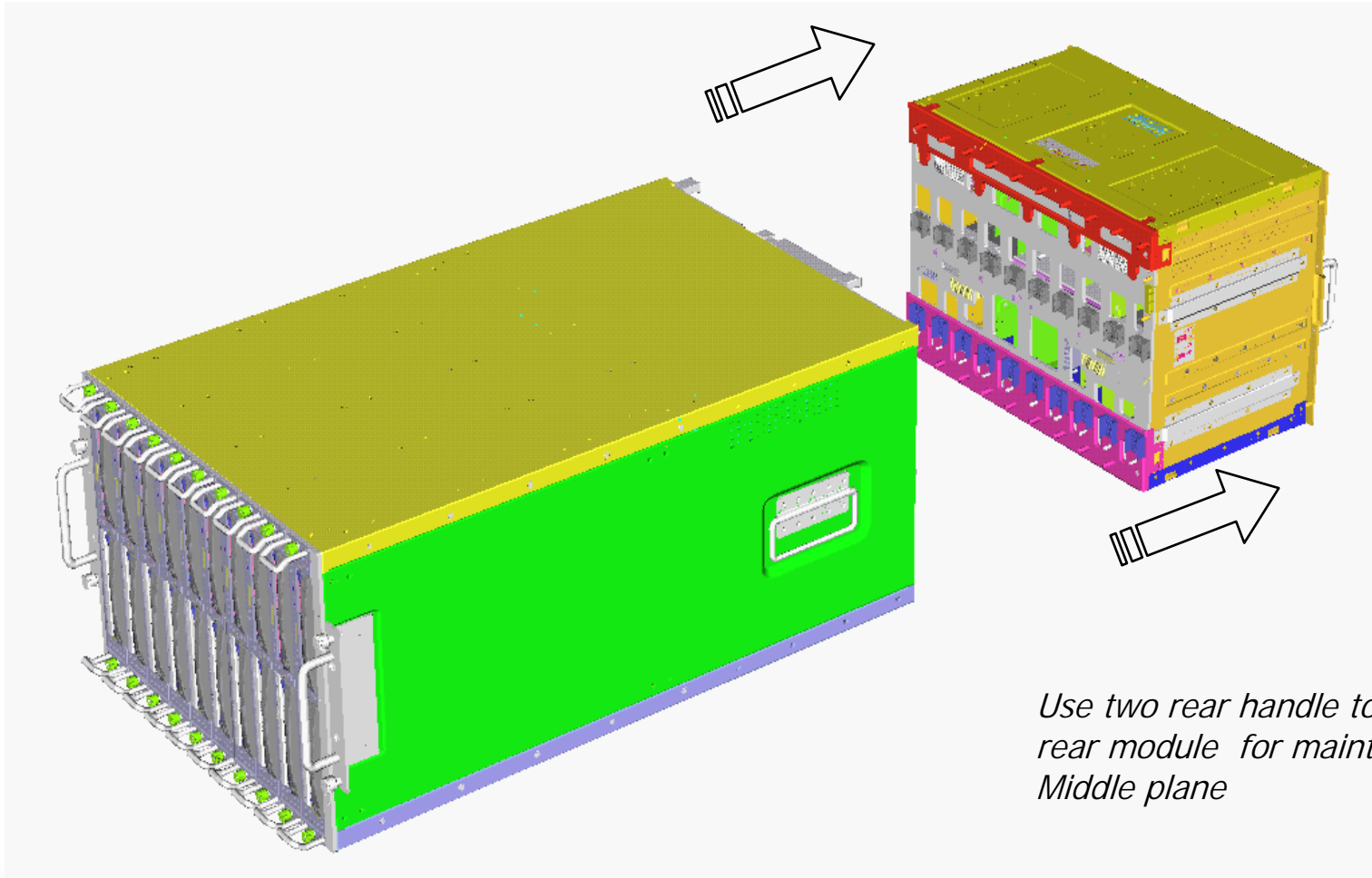

*Use two rear handle to remove rear module for maintain Middle plane*

# Structure

## The View of Inside Board Connecting

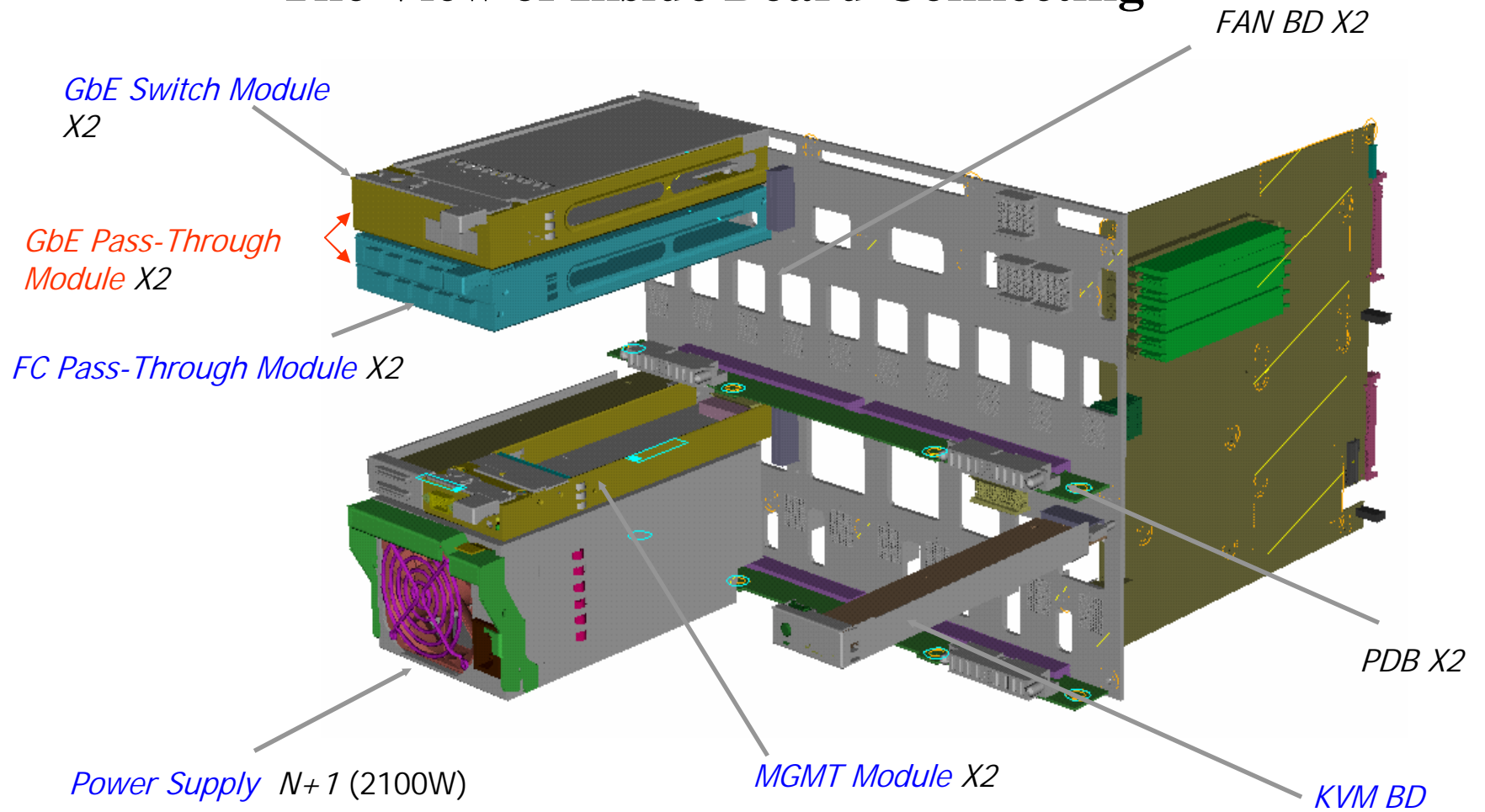

# Mid-plane Placement

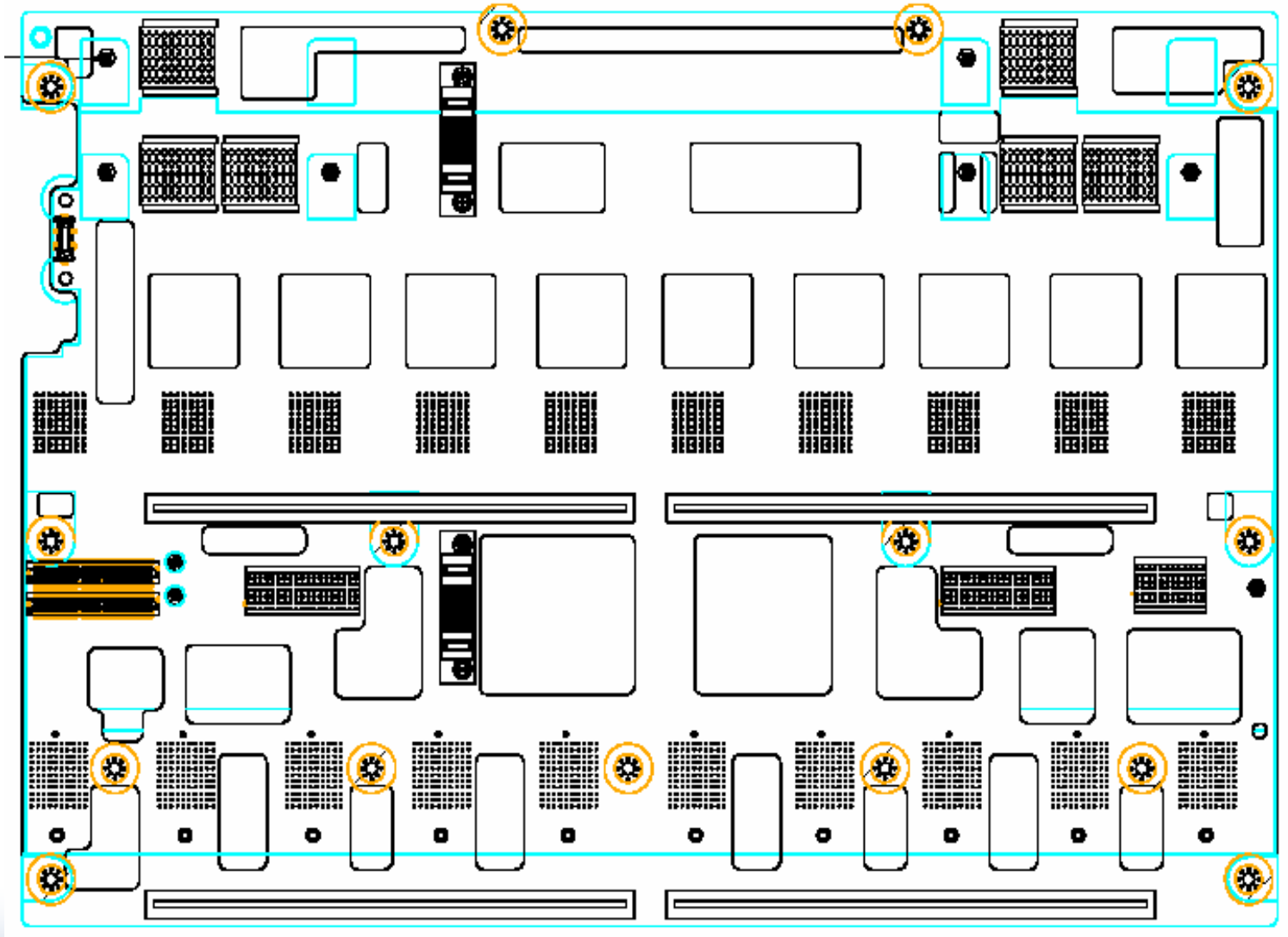

# S75A/B Server Blade

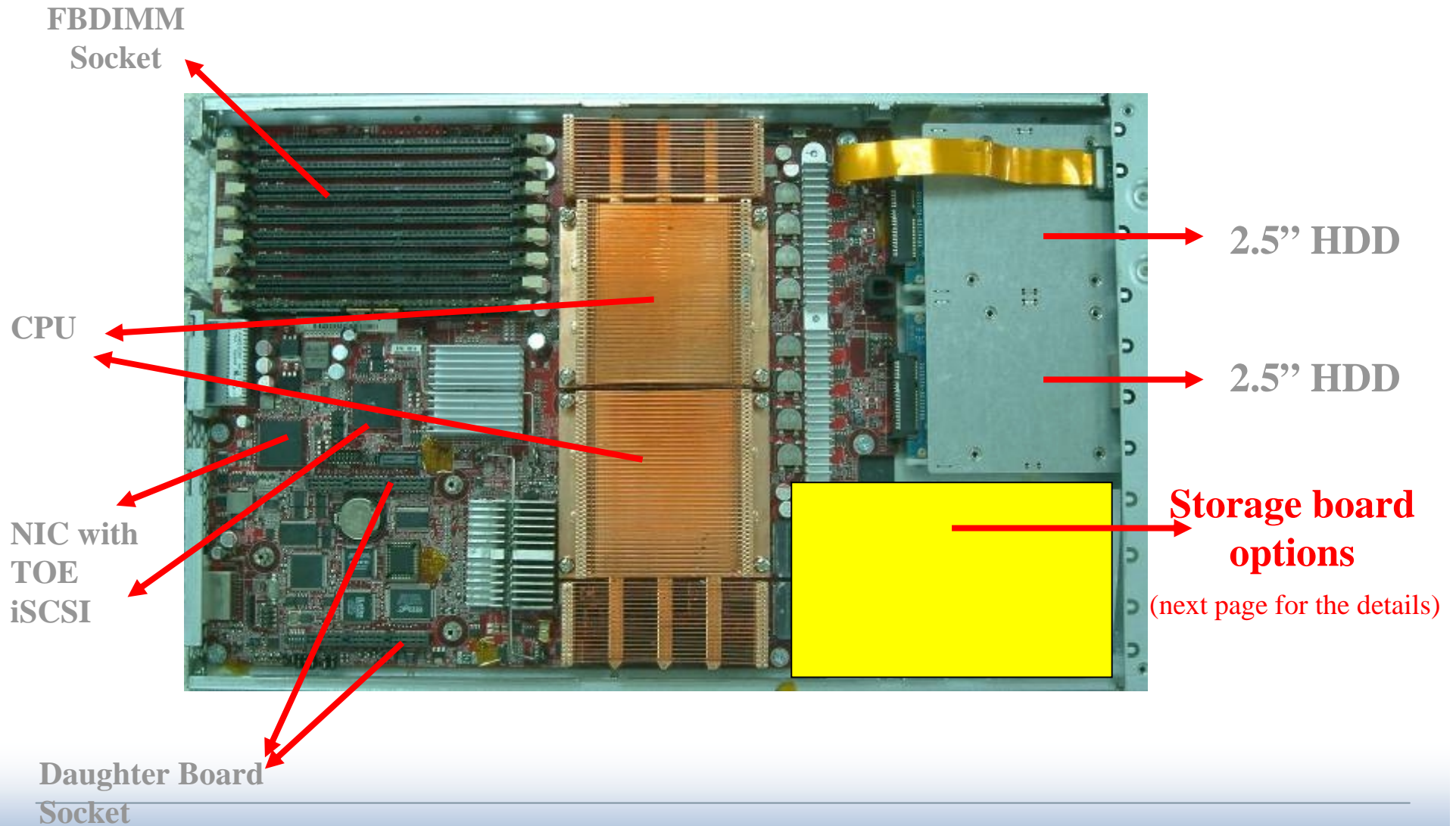

# S75A CPU Blade Specification

	Description
<b>CPU</b>	Intel Xeon Dempsey, Woodcrest, Clovertown LGA771
<b>Chipset</b>	Intel 5000P (Blackford +ESB2)
<b>PCI Slots</b>	One PCI-E (x4) or One PCI-X on front side
<b>Daughter Card</b>	Two PCI-E (x4) or One PCI-X
<b>MB Form Factor</b>	13.1 inches X 10.5 inches, 10 Layers
<b>VGA</b>	ATI RN50 w/ VRAM 16MB
<b>System Memory</b>	8 x DDR2-533/667 FBD (Up to 32GB)
<b>I/O Port (to Mid-Plane)</b>	Two Serdes LAN, VGA, COM, One USB, Two PS2
<b>I/O Port (Front)</b>	Two USB2.0, One VGA, Four LED(NIC, Power, Event, ID), Two SW (Power, ID)
<b>GbE LOM</b>	Two BCM5708S
<b>Drive Controller</b>	Two SATAII Ports by ESB2 or Two SAS Ports by SAS board (LSI1068)
<b>BMC Controller</b>	H8 (HD64F2168)
<b>Power Supply</b>	From Rear side Redundancy Power Supply (Max 420W/Per Blade)
<b>HDD</b>	Two SAS/SATA 3.0G
<b>RoHS Compliance</b>	Yes

# S75A/B CPU Blade Block Diagram

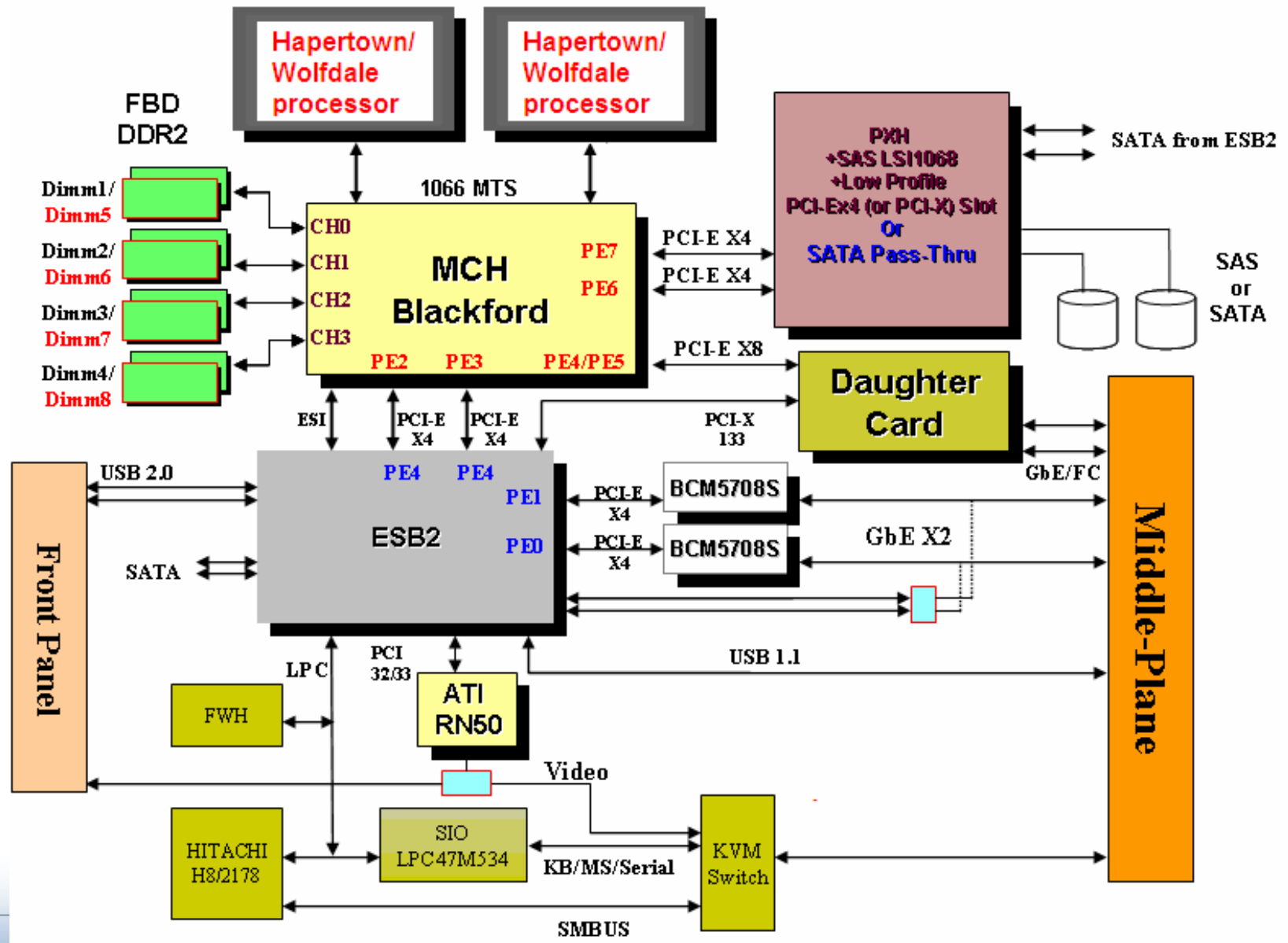

# S75A/B CPU Blade Placement

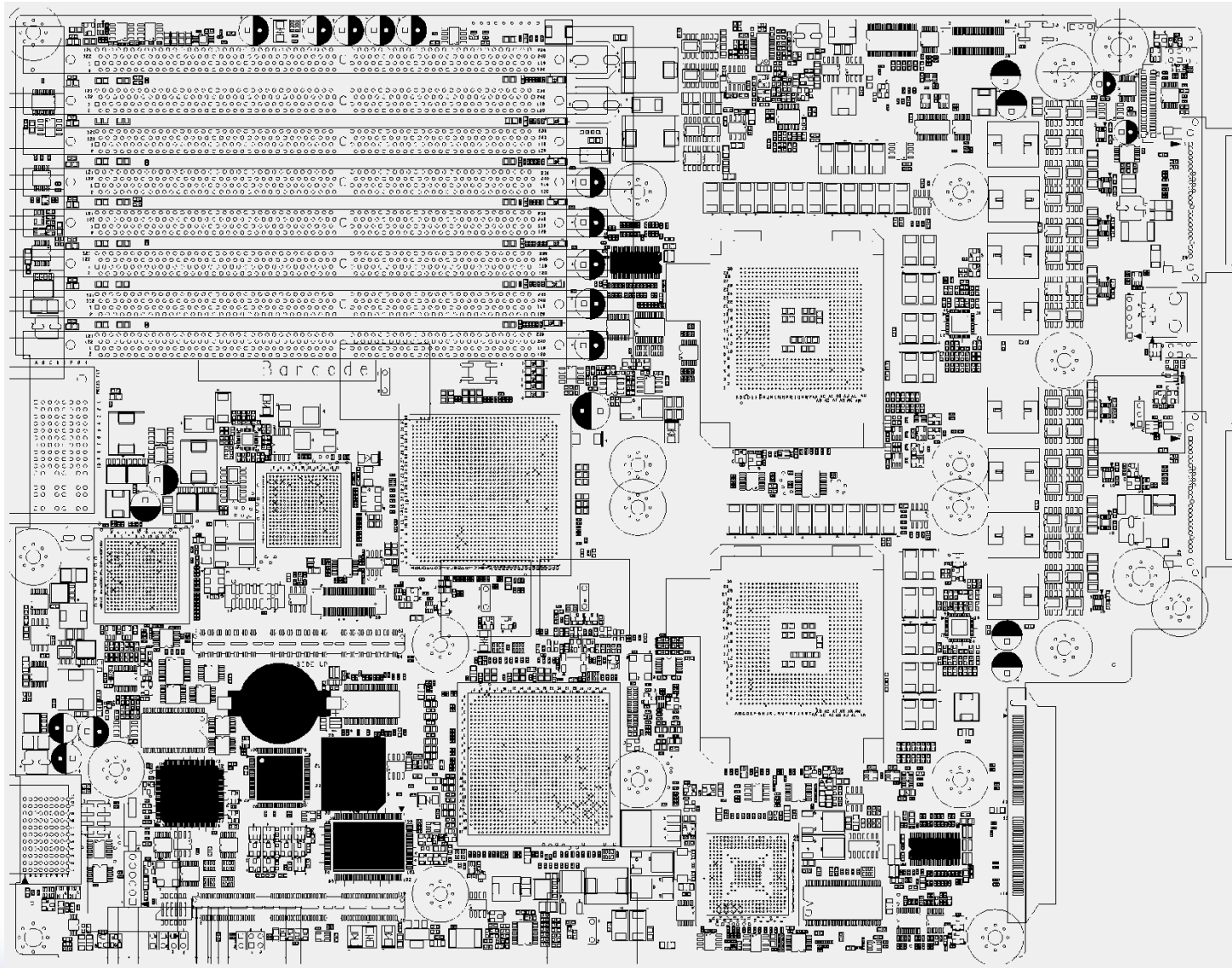

# Redundancy MMB and KVM Module

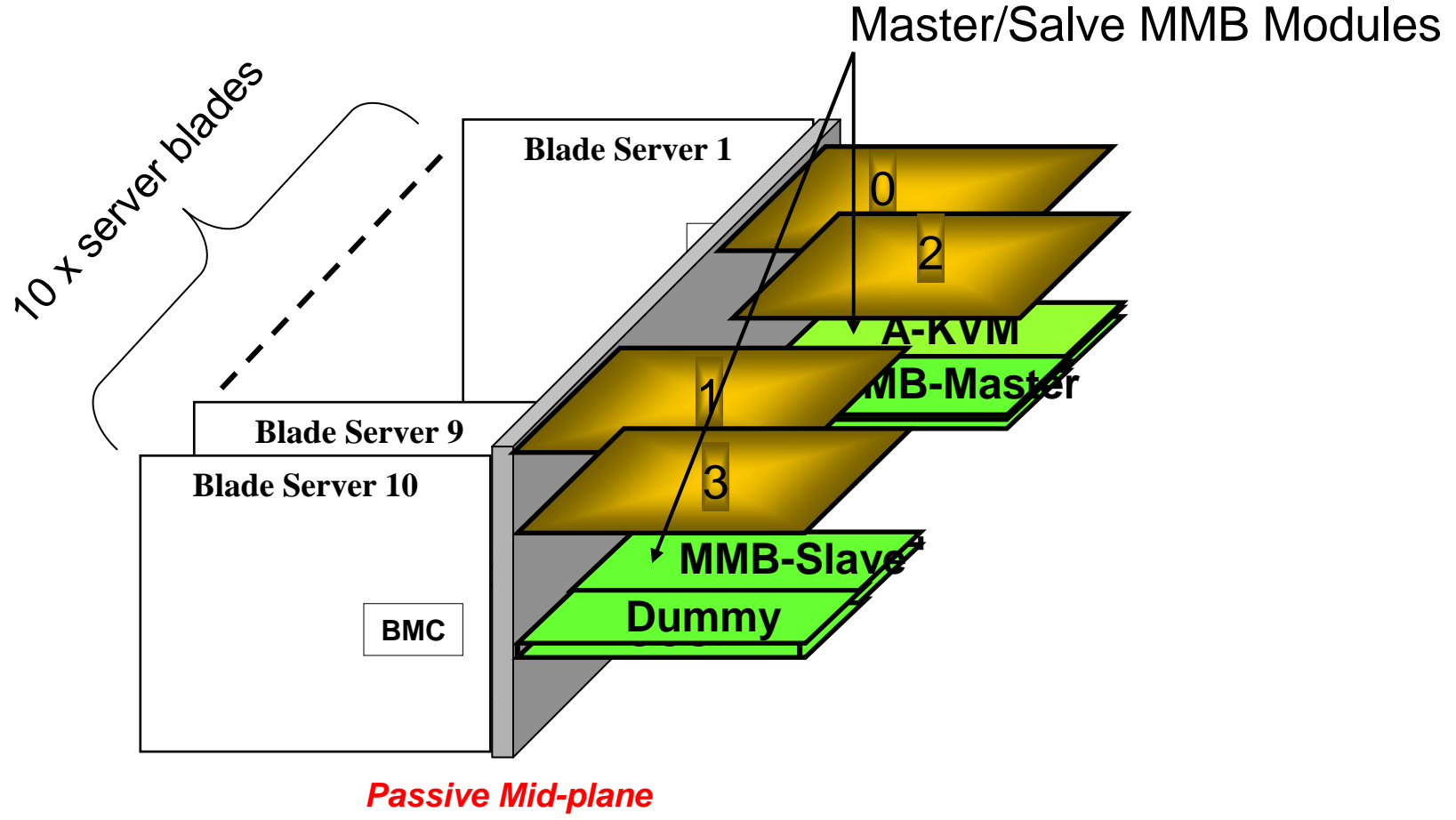

# MMB1/2 Interconnect

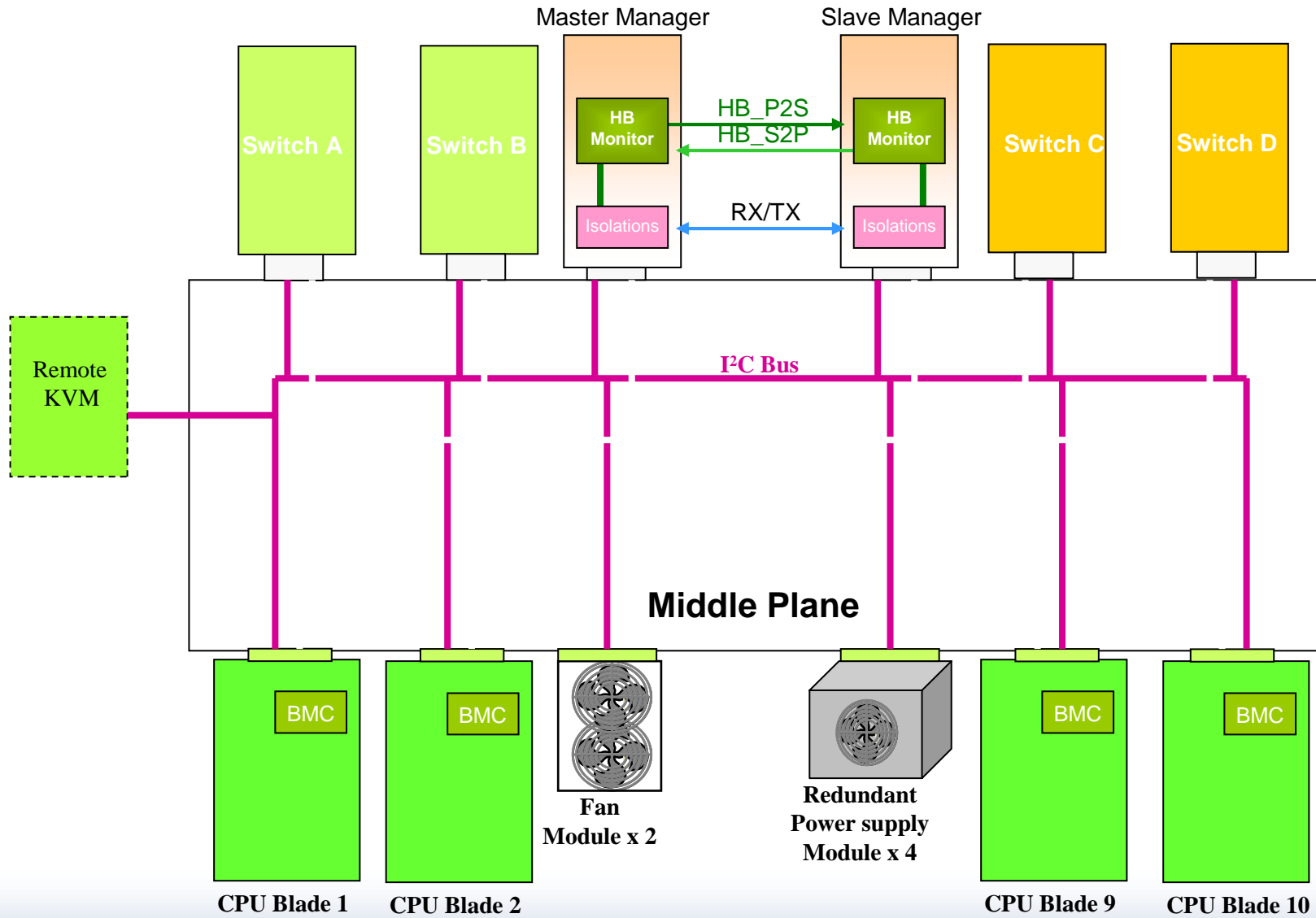

# Architecture for Low Speed Interconnect

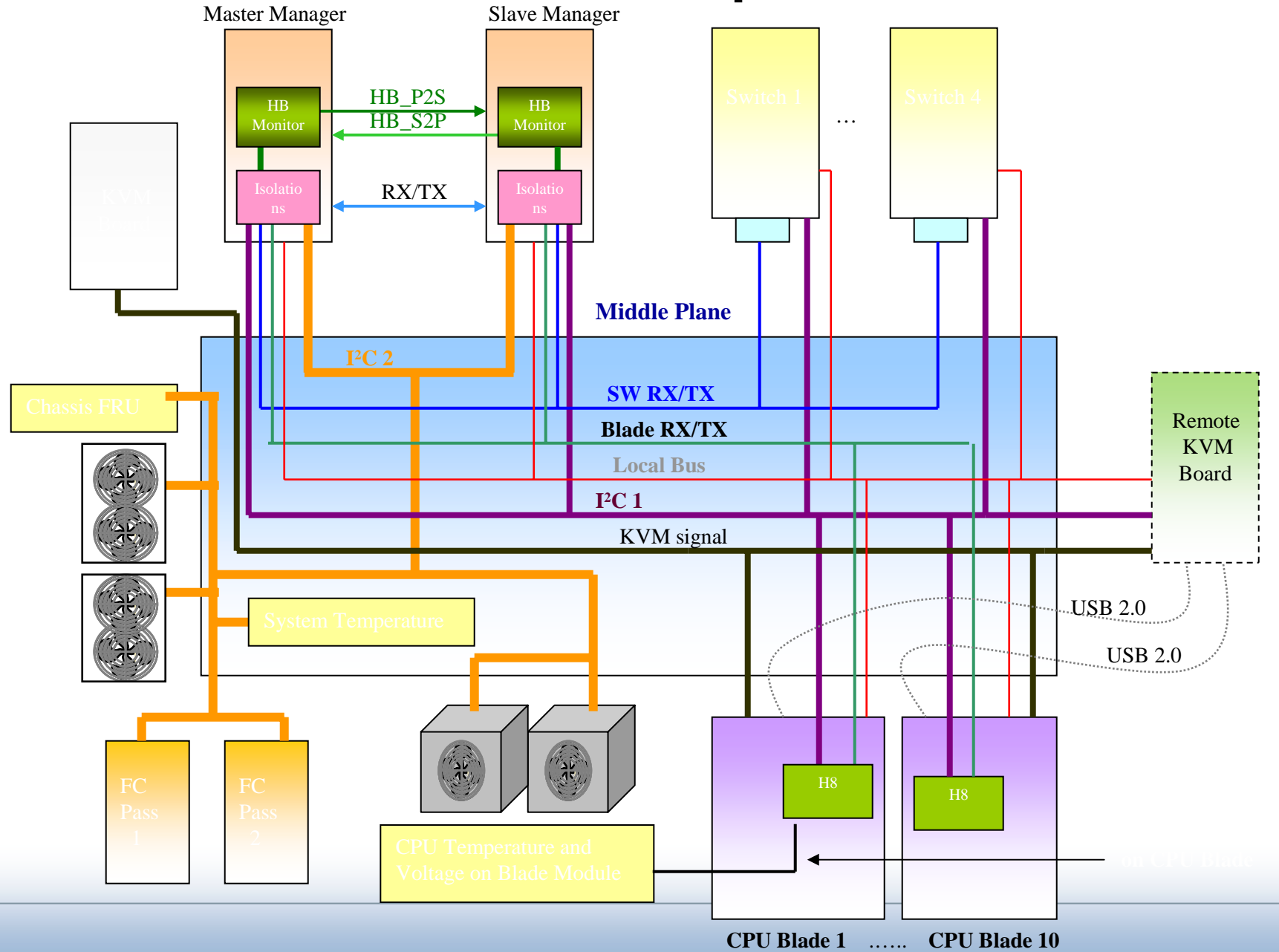

# Block Diagram of I<sup>2</sup>C Channel 1

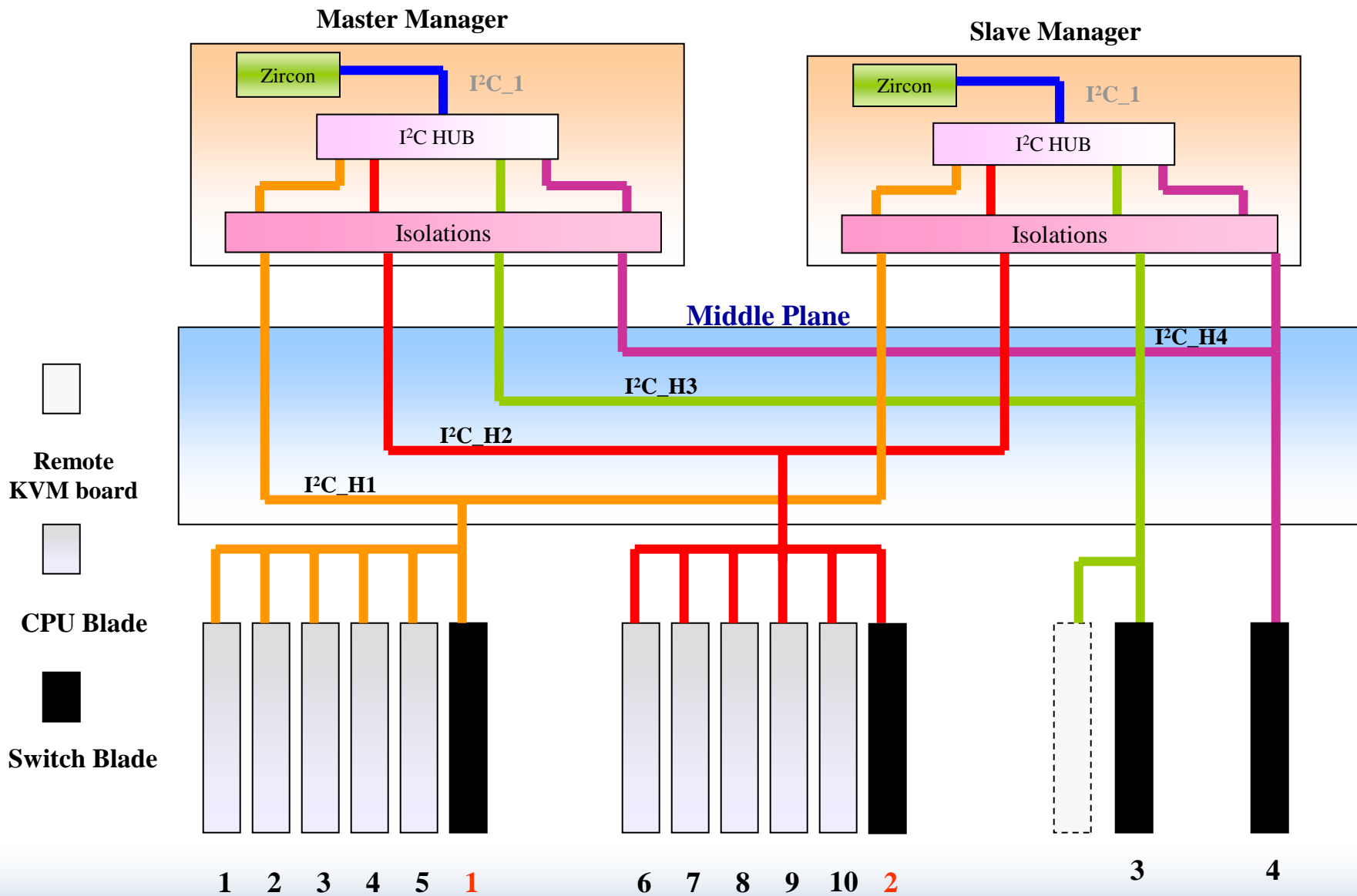

# Block Diagram of I<sup>2</sup>C Channel 2

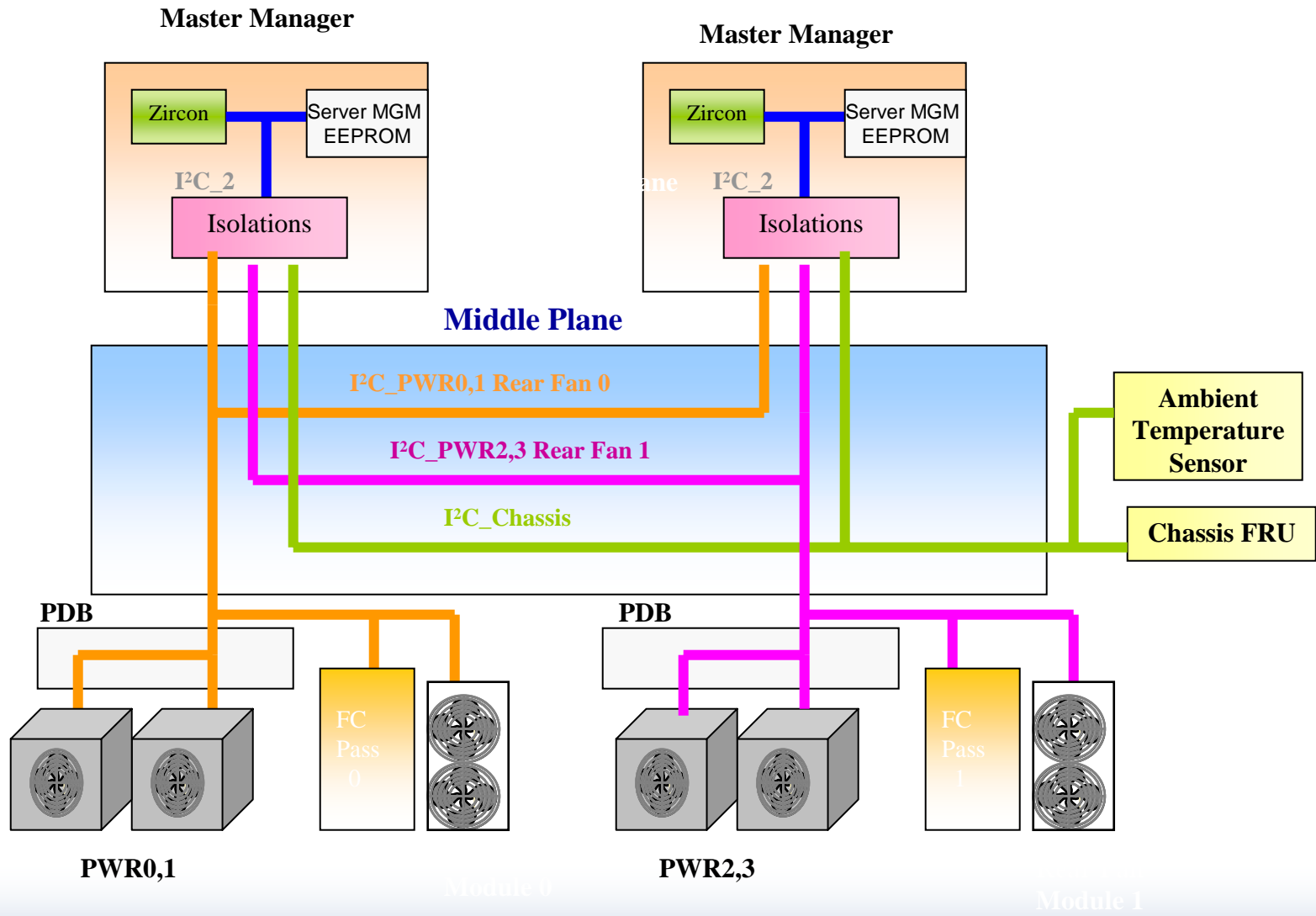

# Dual Redundant Fabrics

Fabric 1 : From On-Board to I/O 0 and I/O 1 Slots

Fabric 2 : From Optional Daughter Card to I/O 2 and I/O 3 Slots

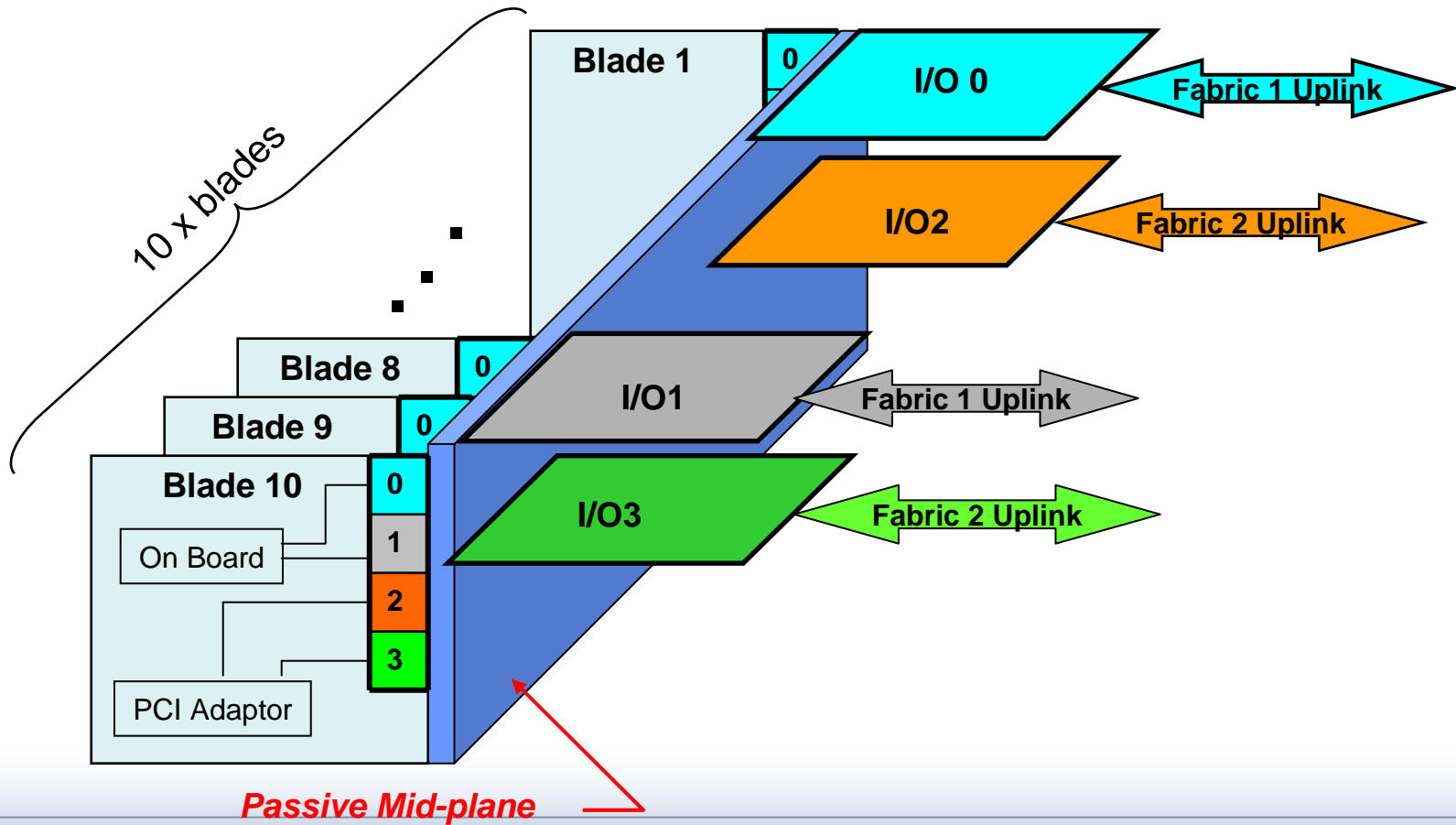

# Front I/O Modules (optional)

## SAS Base Board

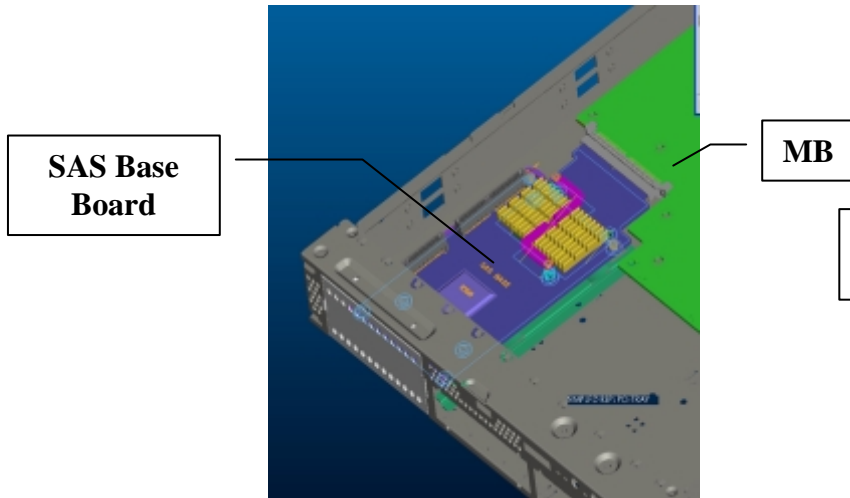

## SATA Bridge Board

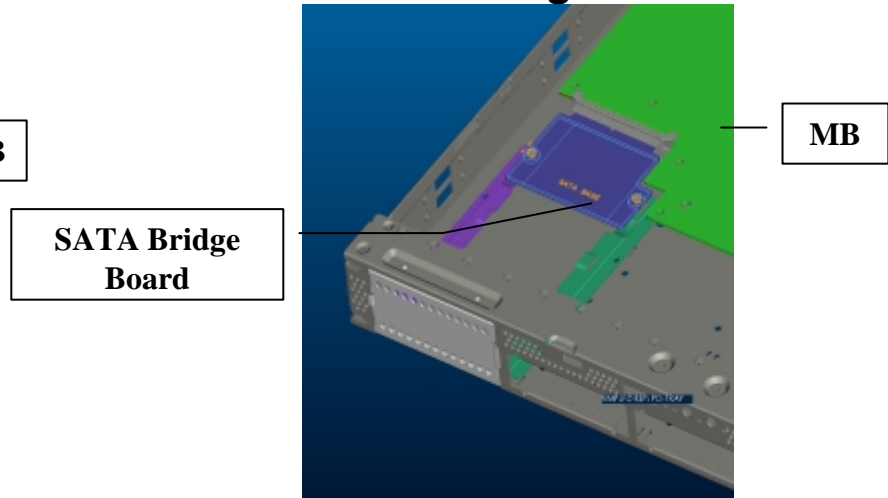

## SAS Base Board + PCI-X Riser

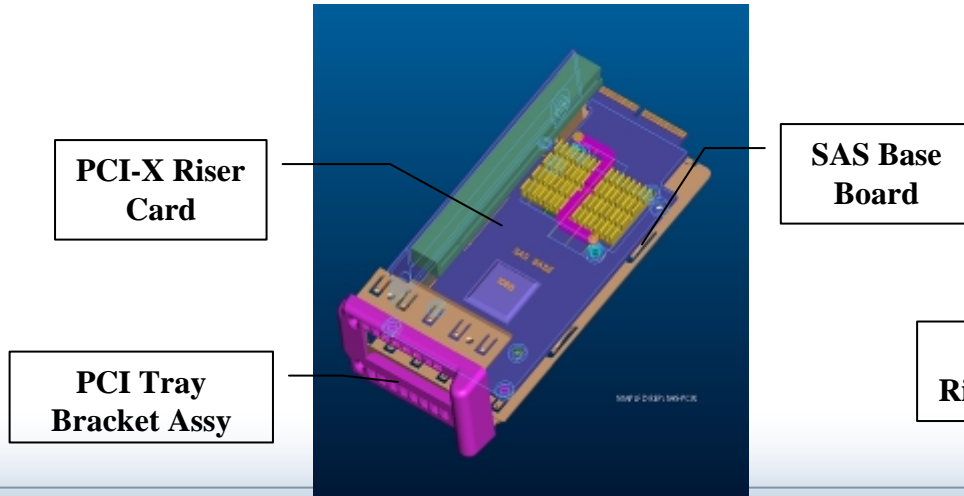

## SAS Base Board + PCI-E Riser

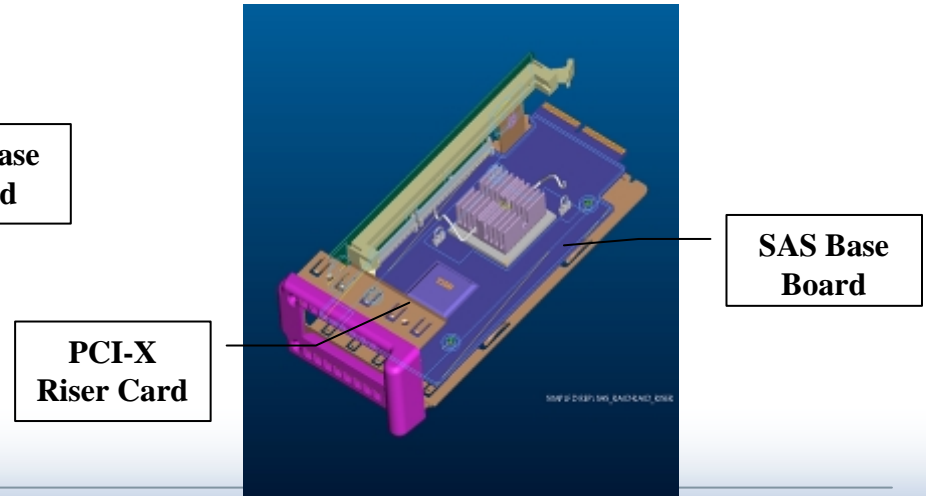

# Rear I/O Modules (Optional)



## Management Blade (MMB)

- Support Out-f-band Management Function
- External Interface Through 10/100 LAN or RS232

## Basic KVM Module(K01)

- KVM Direct Interface Through Y-cable

## Advance KVM Module (G01)

- KVM over IP (10/100 LAN) Interface



# Rear I/O Modules (Optional)

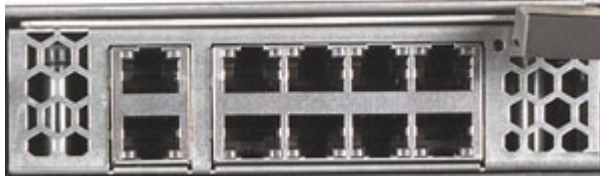

## GbE Pass-Through Module

- 10-Channel Internal SerDes Interface
- 10-Channel External RJ45 Interface

## FC Pass-Through Module

- 10-Channel Internal Interface
- 10 External SFP Interface

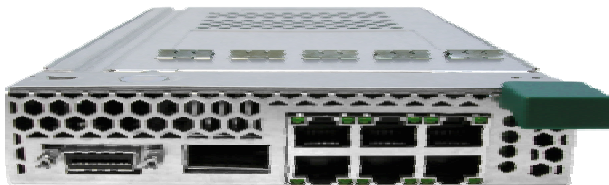

## 10Gb Lan port Switch

- 10-Channel Internal SerDes Interface
- 6-Channel External RJ45 Interface
- CX4 & XFP External 10GbE Interface

# PCI Daughter Card (Optional)



Installed on Server board

- **Host Interface**

- One PCI-X 64-bit/133MHz bus
- One PCI-E (x8) or two PCI-E (x4) buses
- PCI-E Support 2.5Gb/s

- **I/O interface**

- Two I/O channels
  - I/O channel supports 3.125Gb/s
-

# Why Pioneer Blade Server?

## Benefit

Good Cooling and Power System

Scalability

High MTBF - 100% Passive Mid-plane

Lower Cost and High Quality

KVM over IP Supported

No Interoperability Issue